

## OPERATING MANUAL SHREDDER AND BALING PRESS COMBINATION



# HSM<sup>®</sup>

## ***Powerline SP 5088***

Translation of the original operating instructions

HSM GmbH + Co. KG  
Austrasse 1-9  
88699 Frickingen / Germany  
Tel. + 49 75 54 2100-0  
Fax + 49 75 54 2100-160  
info@hsm.eu  
www.hsm.eu

# Contents

<b>Name plate</b>	<b>6</b>
<b>Preface</b>	<b>7</b>
<b>1 Safety</b>	<b>8</b>
1.1 Safety instructions .....	8
1.1.1 The “Work safety” symbol .....	8
1.1.2 The “Note” symbol .....	8
1.2 Classification of hazards.....	8
1.2.1 Danger .....	8
1.2.2 Warning.....	8
1.2.3 Caution .....	8
1.3 Notes on work safety .....	9
1.4 Proper use .....	11
1.5 Inspecting the safety devices .....	12
<b>2 Technical data</b>	<b>16</b>
2.1 KP 88.2 channel baling press.....	16
2.1.1 Press data.....	16
2.1.2 Motor data.....	16
2.1.3 Hydraulic system .....	16
2.1.4 Pump .....	16
2.1.5 Cylinder.....	16
2.1.6 Oil tank.....	16
2.1.7 Noise emission .....	16
2.2 FA 500.3 shredder .....	17
2.3 Power requirement and fuse protection (3 x 400 V / 50 Hz) .....	17
2.4 Operating conditions.....	17
2.5 Accessory.....	17
2.6 SP 5088 diagram.....	18
2.7 Machine dimensions.....	19
<b>3 Installation</b>	<b>20</b>
3.1 General instructions.....	20
3.2 Installation conditions .....	20
3.3 Supply connections .....	20
3.4 Settings.....	20
3.5 Transporting the baling press .....	21
3.5.1 Transporting to another installation site .....	21
3.6 Transporting the shredder .....	22
3.7 Assembling the shredder.....	23
3.8 Assembling the shredder and baling press combination .....	24

<b>4</b>	<b>Initial start-up</b>	<b>27</b>
4.1	Baling press operating controls .....	27
4.1.1	Opening the menu .....	29
4.1.2	Selecting the setup mode .....	31
4.1.2.1	Opening the press channel.....	31
4.1.3	Setting the user language.....	31
4.1.4	Actual values .....	32
4.1.5	Automatic start operating mode.....	32
4.1.7	Displaying actual values .....	33
4.1.8	Settings.....	34
4.2	Shredder control panel .....	35
4.2.1	Display: Baling press not in automatic mode.....	35
4.2.2	Display: Baling press operating state .....	35
4.3	Initial start-up.....	36
4.4	Loading the baling press .....	37
4.4.1	Setting the press channel adjustment cylinder .....	39
4.4.2	Relieving the press channel.....	40
4.5	Inserting the strapping tape .....	41
4.6	Automatic compressing using the light barrier.....	42
4.7	Sequence for “Strap bale” and “Strapping” .....	42
4.8	“Polythene bag attachment” sequence.....	44
4.9	Baling press malfunctions.....	45
4.9.1	Error numbers.....	45
4.10	Shredder malfunctions.....	46
4.10.1	Overload due to paper jam .....	46
4.10.2	Electric motor overheats .....	46
4.10.3	Emergency stop actuated .....	46
4.10.4	Oil reservoir empty.....	47
4.11	Stopping the machine.....	47
4.12	Outdoor operation.....	47
<b>5</b>	<b>Inspection and maintenance work</b>	<b>48</b>
5.1	Notes on maintenance.....	48
5.2	Maintaining the baling press.....	49
5.2.1	Changing the hydraulic fluid/ventilation filter .....	49
5.2.2	Lubricating moveable parts.....	50
5.2.3	Emptying the dirt drawer .....	51
5.3	Maintenance of the FA 500.3 shredder .....	52
5.3.1	Lubricating the drive chains and synchronous wheels (twice a year).....	52
5.3.2	Tightening the tension on the conveyor belt .....	53
5.3.3	Checking the directional stability of the conveyor belt.....	53
5.3.4	Checking the conveyor belt for wear .....	53
5.3.5	Emptying the sump tray .....	54

<b>6</b>	<b>Storage</b>	<b>55</b>
<b>7</b>	<b>Disposal information</b>	<b>55</b>
7.1	Disposal verification form .....	56
<b>8</b>	<b>Using and ordering spare parts</b>	<b>57</b>
8.1	Customer service address.....	57
<b>10</b>	<b>Declaration of Conformity</b>	<b>59</b>

# Name plate

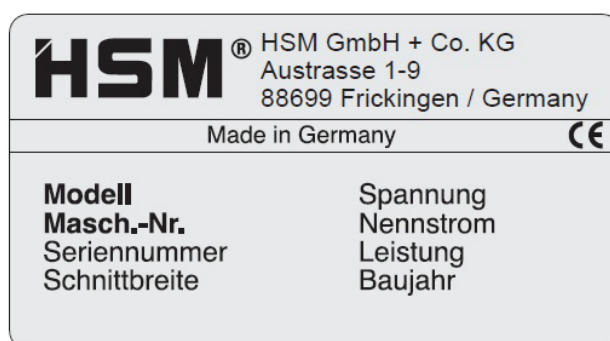
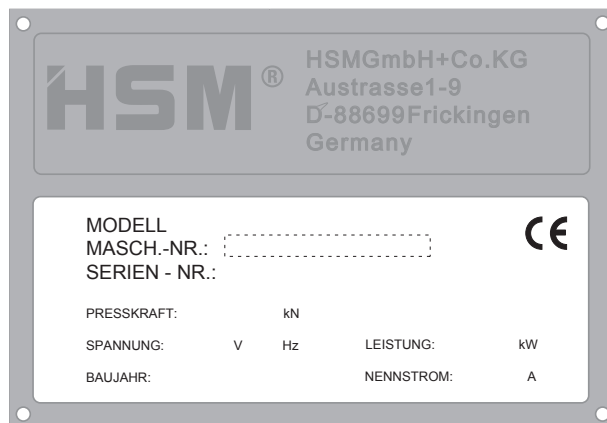

The machine number is indicated on the name plate on the shredder and baling press (above). Warranty claims and queries cannot be dealt with unless you quote the machine number.

# Preface

This operating manual contains detailed instructions on setting up and servicing your new shredder and baling press combination. It also contains safety instructions which must be observed.

Your machine will only perform to its maximum potential if you use it properly and carry out regular and thorough maintenance. Therefore read this operating manual and the safety instructions carefully before you first start the machine and always keep it within easy reach. This helps to prevent accidents, upholds the manufacturer's guarantee and ensures that the machine is functional and ready for operation at all times.

*HSM GmbH + Co. KG* is always striving to improve its products and therefore reserves the right to make alterations and improvements as it deems necessary. However, this does not include an obligation for subsequent modification of equipment already delivered.

We reserve the right to make technical modifications which may lead to variance from the descriptions and illustrations in this manual.

This operating manual is intended for staff who assemble, operate, and service the machine. It contains regulations and technical drawings which may not be reproduced in part or in full, circulated or used without authorisation for the purposes of competition, or passed on to third parties.

If you have any queries after reading this operating manual, please contact your authorised dealer.

# 1 Safety

## 1.1 Safety instructions

### 1.1.1 The “Work safety” symbol



You will see this sign next to all operating safety instructions in this manual where the failure to comply may result in **injury or death**. Observe these instructions and exercise particular care in such cases. Pass on all safety instructions to any other persons using the machine.  
In addition to the instructions in this manual, the safety and accident prevention regulations which generally apply must also be observed.

### 1.1.2 The “Note” symbol



This symbol indicates particularly important instructions in this manual which must be observed in order to ensure guidelines and regulations are correctly adhered to, work is carried out in the proper order, and damage to the machine or other plant components is prevented.

## 1.2 Classification of hazards

### 1.2.1 Danger



Indicates an immediate danger. Failure to heed this warning **will** result in death or very serious injury.

### 1.2.2 Warning



Indicates a potentially dangerous situation. Failure to heed this warning **may** result in death or very serious injury.

### 1.2.3 Caution



Indicates a potentially dangerous situation. Failure to heed this warning **may** result in minor injury.  
Also used to warn about material damage.



## 1.3 Notes on work safety

### Pay particular attention to the following safety instructions:

- The SP 5088 shredder and baling press combination has been inspected for safety by an accredited test and certification board.  
Nevertheless, incorrect operation and misuse can result in:
  - Serious or fatal injury to the operator
  - Damage to the machine and other material assets of the company
  - Inefficient machine operation
- The SP 5088 shredder and baling press combination has been built with the most up-to-date technology. However, the machine can be dangerous if improperly used, even by trained staff, or if used for purposes other than those for which it was designed.
- The operation of the shredder and baling press combination is always subject to local safety and accident prevention regulations.

The employer must observe and adhere to the “minimum requirements for health and safety protection for the use of work equipment by employees at work”.  
(Machinery Directive 2009/104/EC)

- The shredder and baling press combination may not be operated by anyone under 16 years of age.
- All those charged with installation, disassembly, re-assembly, inspection, maintenance or repair of the press must have first read and fully understood the entire operating manual, paying particular attention to the “Safety” section.
- The shredder and baling press combination may only be operated, serviced and repaired by authorised, trained staff. These staff must have been given special instructions on any dangers which may arise.
- Areas of personal responsibility for installation, disassembly, re-assembly, set-up, operation and maintenance must be clearly defined and strictly adhered to, in order to avoid confusion which might compromise safety.
- When carrying out installation, dismantling, re-assembly, set-up, operation, adjustment and maintenance work, always observe the shut-down procedures described in the operating manual. Never perform this kind of work on the machine unless it is fully shut down.
- Before performing such tasks, make sure the drives and additional mechanisms of the machine cannot be switched on unintentionally. Turn the main switch to the “0” position and secure it. Pull out the power plug.
- Before starting the machine after maintenance work, make sure that all protective devices are in place.
- Electrical and hydraulic safety components must be replaced in accordance with the service life specifications in the original manufacturer’s instructions, but at least every 20 years.



- Do not carry out any tasks which may endanger your safety while operating the machine.
- Any changes which take place and could impair safety should be reported immediately.  
Put the machine out of operation until the damage is rectified.
- Always make sure the machine is in perfect condition before you switch it on.
- Make sure the area around the machine is clean and safe.
- Unauthorised modifications and changes to the machine are strictly prohibited.  
Safety devices may not be removed or otherwise rendered inoperative.
- No work on the machine which is not part of its normal operation may be performed while the machine is still running.
- Never open doors and flaps before the machine has been shut down.  
Note the instruction plate.
- Test the protective measures installed after any electrical or repair work.
- No platforms or other raised surfaces may be placed near the shredder and baling press combination if they encroach on the specified safety clearances.
- Connecting cables must be laid in such a way that they cannot be tripped over.
- Only persons with the appropriate skills and experience in hydraulics may carry out work on the hydraulic equipment.
- All lines, pipes and bolted joints must be regularly inspected for looseness, leaks and visible damage. Any damage must be repaired immediately. Escaping oil can cause a fire and injury.
- Any parts of the system and hydraulic pressure lines that need to be opened/ disconnected must be de-pressurised according to the assembly instructions before commencing repair work.

## 1.4 Proper use

The **SP 5088** shredder and baling press combination is to be used **exclusively** for shredding and compressing paper and cardboard. Its sturdy cutting unit is not damaged by paper clips and staples. In machines with cutting widths of 6 x 40–53 mm, 7.5 x 40–80 mm and 10.5 x 40–76 mm you can also shred entire folders. Other types of material are excluded.

Function sequence:

The above-mentioned material is fed into the shredder. The shredded material falls through the discharge chute of the shredder directly into the press chute. The press cycle is initiated by the light barrier in the chute when it has filled up to a certain level. The press ram is extended and pushes the material into the conical press channel, where it is compacted. The shredder continues to run during the pressing cycle. Once the bale has reached a certain length, it must be manually strapped. Then the pressing cycle can continue.

Due to the continuous press cycle, the compact bales are ejected onto a pallet or into a side-gusseted bag at the end of the press channel.

Any other use is considered **improper**. The manufacturer accepts no liability for damage resulting from improper use. The operator carries sole responsibility for such use.

Proper use also includes carrying out installation, assembly, disassembly, start-up, operation and maintenance work as prescribed by the manufacturer. The machine may only be operated, serviced and repaired by staff who are familiar with these regulations and aware of the dangers.

The shredder and baling press combination may only be operated by authorised, trained staff. Do not carry out any tasks which may endanger your safety while operating the machine.

The relevant accident prevention regulations and any other generally recognised health and safety standards must also be observed.

## 1.5 Inspecting the safety devices

Check the safety devices:

- At the start of each shift (if operation was interrupted)
- At least once a week in case of continuous operation
- Following any maintenance or repair

Ensure that the safety devices are:

- In the prescribed condition
- In the prescribed location
- Firmly attached
- Functioning properly

Use the following check list for your inspection. Correct any defects before starting the machine.

If any defects arise during operation, stop the machine immediately and ensure that the defect is corrected.

Do not modify or remove any of the safety devices. Do not deactivate any of the safety devices by modifying the machine.

Modifications to the machine are prohibited for safety reasons.

# Check list for inspecting the safety devices

Use the following check list to inspect the safety devices.

Photocopy this check list for regular inspections.

Tick off the boxes if the check was successful.



Do not start the machine until you have checked every point.



- 1. All protective covers must be fitted and firmly bolted onto the shredder and baling press. (see picture)



- 2. The control cabinet must be closed and the warning sign with a flash symbol must be affixed to the switch box.



- 3. Check the safety switch on the dirt drawer in the machine. The safety switch switches the shredder and baling press combination off immediately and prevents it from being switched on again when the dirt drawer is opened.

Try this function out.

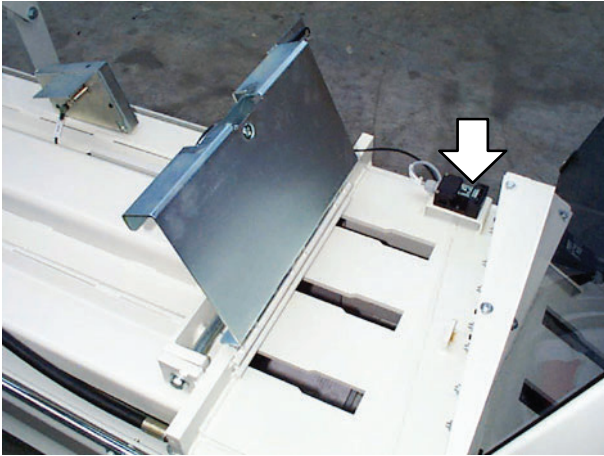

4. Check the safety switch on the strapping flap.  
The safety switch switches the machine off immediately and prevents it from being switched on again when the strapping flap is opened.

Try this function out.



5. Check the safety switch on the loading hopper.  
The safety switch switches the shredder and baling press combination off immediately and prevents it from being switched on again when the dirt drawer is opened.

Try this function out.

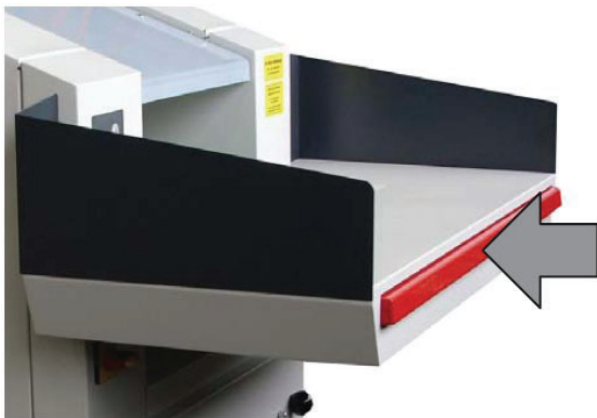

6. If you press the emergency stop button while the machine is running, the shredder and baling press must switch off immediately.  
The machines can only be switched on again once you have pulled out the switch bar.

Try this function out.

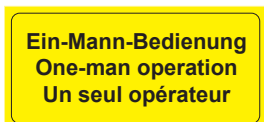

7. The “One-man operation” safety sticker must be affixed to the shredder.



8. The “Safety Symbols” sticker must be affixed to the shredder.

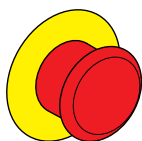

9. If you press the emergency stop button while the machine is running, the shredder and baling press must switch off immediately.

The machines can only be switched on again once you have unlocked the emergency stop button.

Try this function out.

Inspected	
Date	Signed

## 2 Technical data

### 2.1 KP 88.2 channel baling press

Weight	approx. 880 kg
Dimensions	See dimension sheet

#### 2.1.1 Press data

Pressing force	85 kN
Specific pressing power	30 N/cm <sup>2</sup>
Cycle time when idling (theoretical)	13 s
Bale size (W x H x L)	500 x 500 x 400–950 mm
Bale weight (regardless of material)	40 – 70 kg

#### 2.1.2 Motor data

Rated power P <sub>n</sub>	4.0 kW
Operating voltage U	400 V / 50 Hz
Output speed n <sub>ab</sub>	1,450 min <sup>-1</sup>
Protection type	IP54

#### 2.1.3 Hydraulic system

Operating pressure p <sub>Operation</sub>	210 bar
---	---------

#### 2.1.4 Pump

Output Q at 1,450 min <sup>-1</sup>	19.5 l/min
-------------------------------------	------------

#### 2.1.5 Cylinder

Press cylinder	ø70/50 x 630 mm
Adjusting cylinder	ø60/40 x 120 mm

#### 2.1.6 Oil tank

Capacity	27 l
Oil type	Multigrade oil (DIN 51524-T3) ISO viscosity grade HVLP 22

#### 2.1.7 Noise emission

The sound pressure level of the baling press is as follows:

Idle running 1 m / 7 m *)	71/69 dB(A)
Full load 1 m / 7 m *)	82/79 dB(A)

\*) The distance is measured between the testing device and the surface of the machine at the loading aperture.



## 2.2 FA 500.3 shredder

Cutting type	Particle cut			
Cutting size (mm)	10.5 x 40–76	7.5 x 40–80	6 x 40–53	1.9 x 15
Security level DIN 66399	P-2, O-2, T-2, E-2	P-3, O-2, T-3, E-2	P-3, O-2, T-3, E-2	P-5, O-4, T-5, E-4, F-2
Cutting capacity (sheet), DIN A4 70 g/m <sup>2</sup> 80 g/m <sup>2</sup>	600–650 510–550	500–550 425–470	360 - 410 300 - 350	120–130 90–100
Throughput security level 4				200–250 kg/h
Intake width	500 mm			
Cutting speed	210 mm/s			
Power supply	3 x 400 V, 50 Hz			
Power consumption with max. number of sheets	7.5 kW			5.5 + 4 kW
Plug	Industrial plug			
Safety fuse line safety switch max. mains impedance	Type "gl" 35 amps K or C / 32 amps 0.1517 Ohm			
<b>Ambient conditions for transport, storage and operation:</b> Temperature relative humidity height above SL	-10 °C up to +40 °C max. 90%, non-condensing max. 2,000 m			
Size W x D x H (mm)	1,170 x 1,795 x 1,795			
Weight	790 kg			920 kg
Sound pressure level	75 dB(A)			

## 2.3 Power requirement and fuse protection (3 x 400 V / 50 Hz)

	SP5088 (P2-P4)	SP5088 (P-5)
Rated power $P_n$	11,5 kW	13,5 kW
Rated current $I_n$	32 A	32 A
Plug electrical connection	CEE 32	Industrial plug
Total fuse protection	Shredder and baling press combination 32 A	

## 2.4 Operating conditions

Operating temperature	-10 °C ÷ +40 °C
Operating humidity	Max. 90%, non-condensing
Operating altitude	max. 2,000 m above sea level

## 2.5 Accessory

PE side-gusseted bag	570/545 x 1,150 x 0.1 mm
Item no.:	1.452.995.000

## 2.6 SP 5088 diagram



1. Press switch box
2. Press control panel
3. Inspection flap
4. Press channel adjustment
5. Polythene bag attachment
6. Press channel
7. Tape insertion needle

8. Dirt drawer
9. Strapping flap
10. Hydraulics protective cover
11. Tape station
12. Press cylinder
13. Ventilation filter
14. Hydraulic tank
15. Press motor



16. FA 500.3 shredder
17. Loading tray
18. Document shredder operator control panel
19. Emergency stop switch bar
20. Feed belt
21. Braking/swivel castors
22. Shredder inspection flap
23. Oil reservoir opening

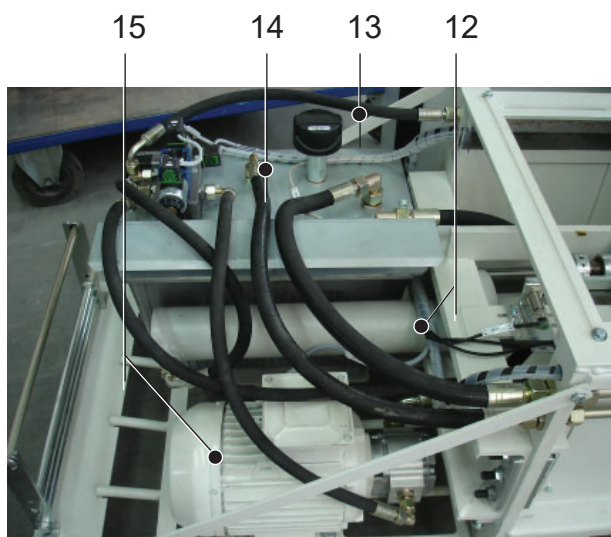



## 3 Installation

### 3.1 General instructions

We strongly recommend that installation work on the baling press should be carried out by trained HSM engineers.

We accept no liability for damage resulting from incorrect installation.

If you do perform installation tasks yourself, make sure you have read and fully understood the entire operating manual before you start.

### 3.2 Installation conditions

When deciding where to install the machine (e.g. planning by the customer), make sure there is enough space around the machine so that assembly and repair work can be carried out without any obstruction. Upstream and downstream equipment should be arranged accordingly.

The shredder and baling press combination must be installed so that it is level.

The shredder and baling press combination may only be operated in dry rooms.

Avoid direct sunlight and adverse weather conditions.

At temperatures below 0 °C and above 30 °C, use a different hydraulic oil with suitable viscosity for the baling press or retrofit tank heating/oil cooler.

### 3.3 Supply connections

Power is supplied via the central control cabinet of the baling press. A connection cable with a CEE connector is in the control cabinet.

The installation site must have a CEE 5x32A/6H socket with a suitable fuse protection. (see "Technical Data")

### 3.4 Settings

Normally the machine is supplied with all the assemblies mounted and hydraulic lines connected.

The electrical and hydraulic settings for the various components have been performed by HSM.



**Caution!**

*Unauthorised adjustments to the set values are prohibited and could seriously damage the machine.*

## 3.5 Transporting the baling press

Always use the special bearing points for unloading the machine from a lorry using a forklift.



- Place the baling press on a smooth level surface at the installation site.
- Remove the packaging and dispose of it in an environmentally responsible manner.
- Cut through the steel straps.
- Using a forklift, lift the baling press by approximately 10 cm and remove the wooden blocks.
- Open the inspection flaps and remove all the enclosed objects from the press chamber.

### 3.5.1 Transporting to another installation site

If only a short distance has to be covered, the channel baling press can be rolled to the installation site.

At the new installation site, the floor must be sufficiently resistant and the space requirement must be met as well as containing an appropriate electrical connection.



**Caution!**

*Installations on the electrical system or control cabinet may only be carried out by a qualified electrician or one of our service engineers.*

## 3.6 Transporting the shredder



### **Caution!**

*When moving the shredder, note that it may topple over.  
Risk of tipping!*

- Place the shredder on a smooth level surface at the installation site.
- Remove the packaging and dispose of it in an environmentally responsible manner.
- Cut through the steel straps.
- Roll the shredder off the pallet according to the instructions for unpacking.  
The shredder can now be moved on its rollers.



- The loading table must be assembled at the installation site.



### 3.7 Assembling the shredder

The shredder is not fully assembled on delivery.  
The loading table is not mounted and should only be mounted at the installation site.

- Attach the table using the M 10 nuts (1)

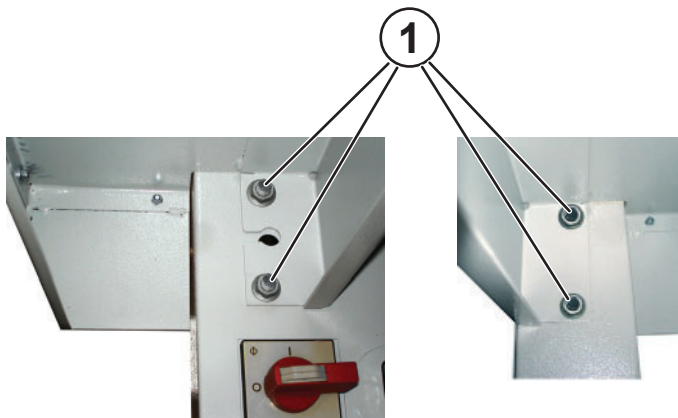
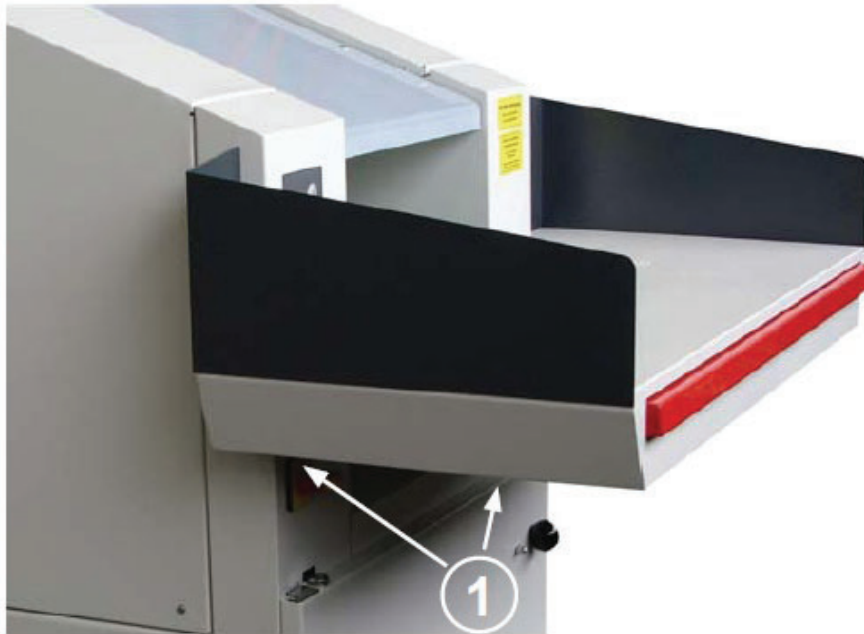

- Insert the plug (connection for emergency stop switch bar) into the socket and lock it into place.



### 3.8 Assembling the shredder and baling press combination



**Danger!**

Open cutting elements, blade rollers.  
Can cut off fingers and hands.

Neither the shredder nor the combination press may be switched on before both devices are properly connected and bolted together.

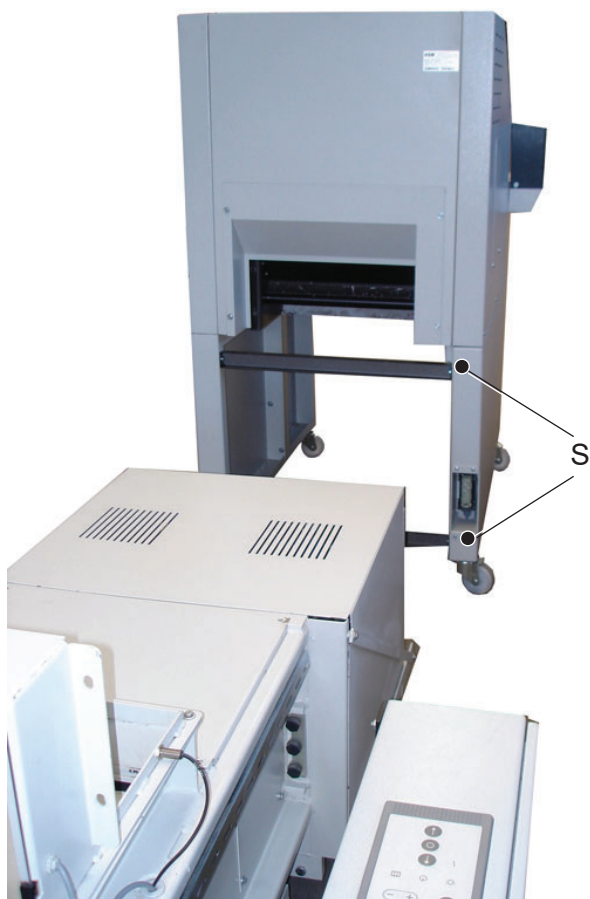

1. Dismantle the 2 cross members (S) on the shredder and lock the braking castors on the press.

2. Push the shredder over the press from behind.

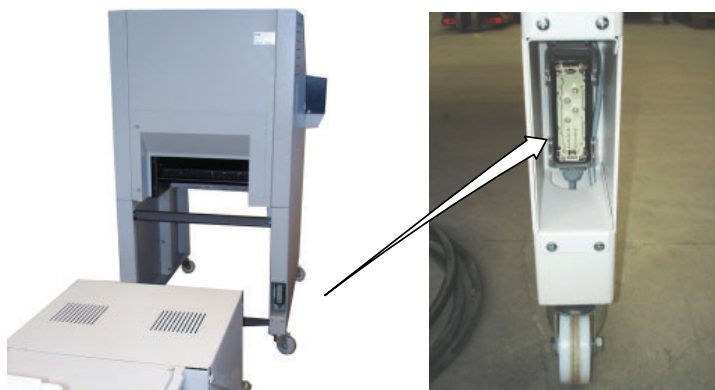

3. Insert the plug of the connection cable into the socket of the shredder and lock it into place.



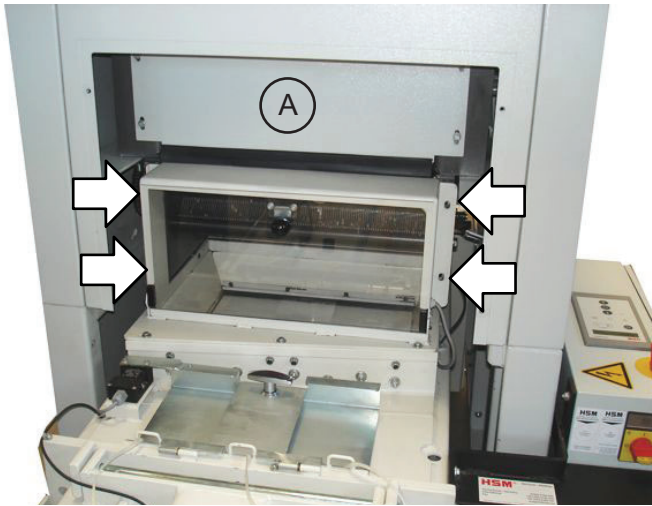

4. Carefully push it forward until the discharge chute of the shredder touches the press loading hopper. Watch out for the cable!
5. If the shredder cannot be completely pushed up to the press shaft, loosen the cover (A) and then tighten it again.
6. Screw the shredder and the baling press together using the 4 nuts.

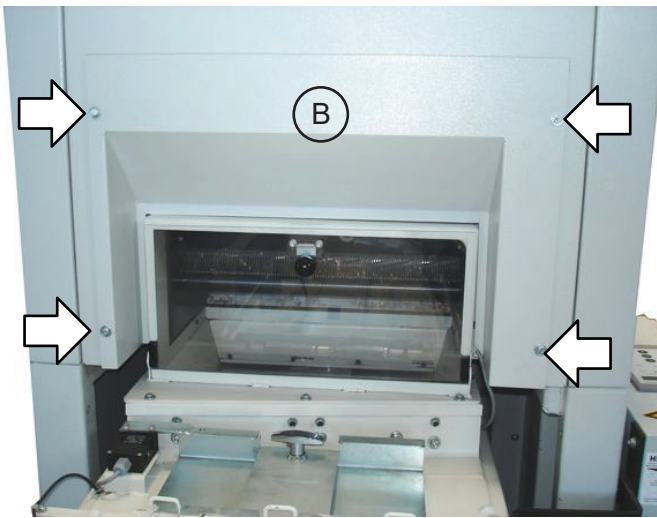

7. Screw on the cover plate (B) firmly using the 4 oval head cap screws.



8. Insert the plug of the connection cable into the socket of the baling press and lock it into place.

10. Now lock the braking castors on the shredder.



11. Check the safety devices.  
Use the check list in chapter 1 to perform the check.



## 4 Initial start-up

### 4.1 Baling press operating controls

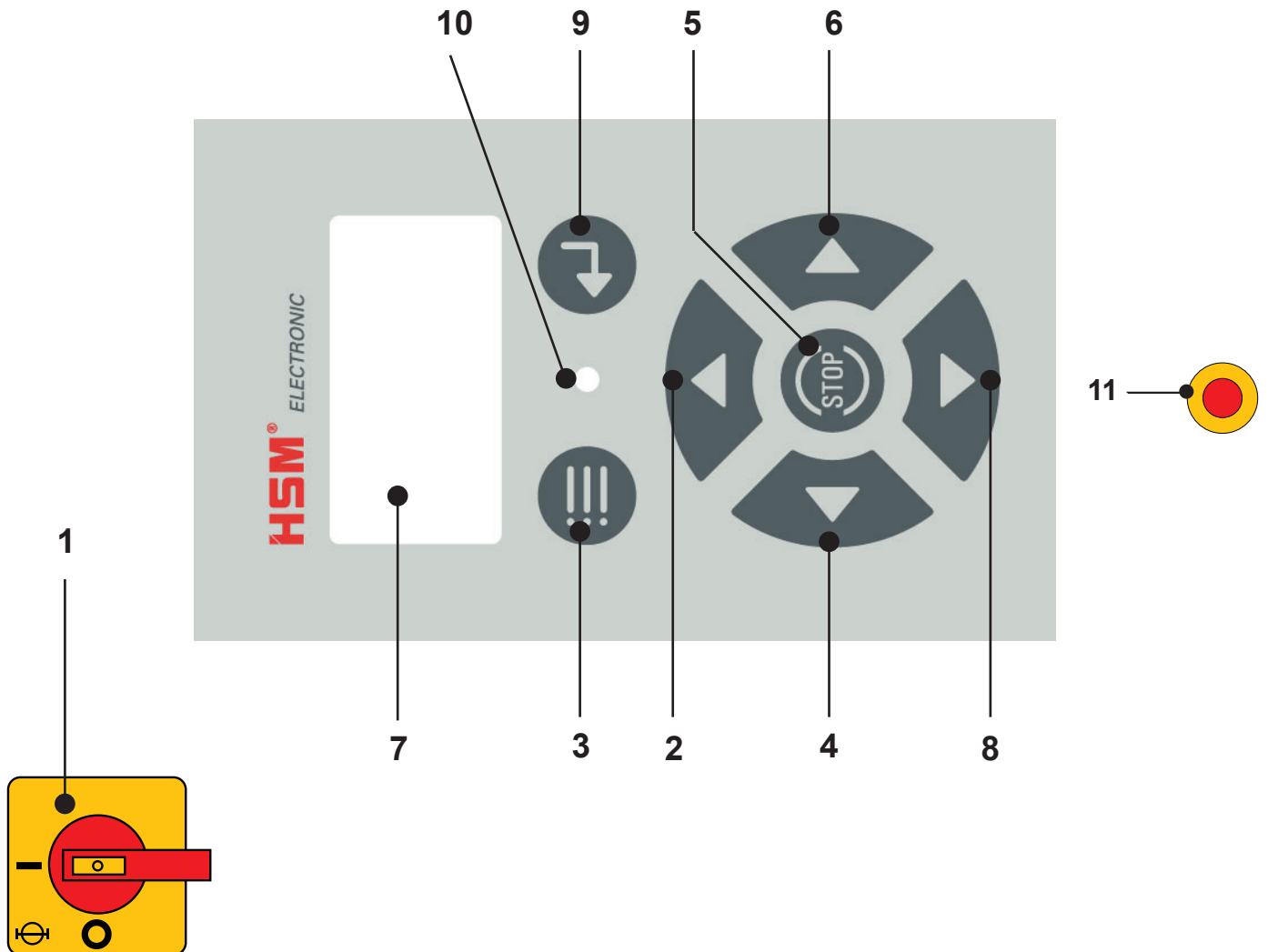

- 1 Main switch
- 2 Vertical navigation
- 3 Menu button
- 4 Horizontal navigation
- 5 Stop button
- 6 Horizontal navigation
- 7 Display
- 8 Vertical navigation
- 9 Enter (input button / acknowledge fault)
- 10 LED (2 colours) green / red
- 11 Emergency stop (optional)



### Main switch (1)

The main switch is on when it is turned 90° to the right.  
In the “Off” position, the main switch can be secured with a padlock.

### Display (2)

Messages are shown in the display. (-> see also “Malfunctions”)



### Menu button (3)

Open the menu.



### Enter (4)

This button confirms the entry.



### Control keys ( )

These buttons are used for making service settings.

The buttons are assigned in the same way as on a numerical block.

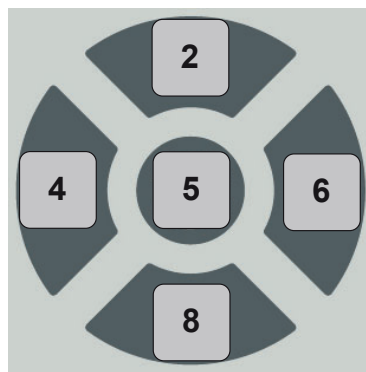









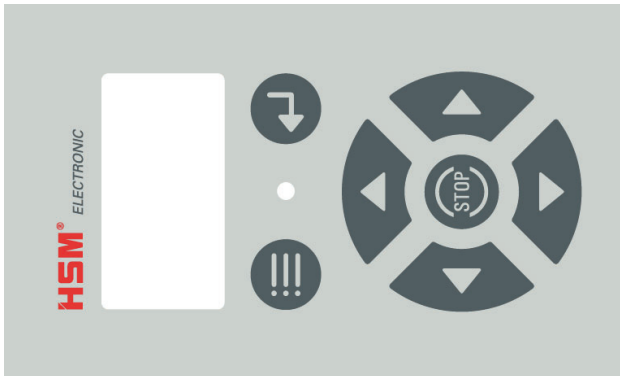

### 4.1.1 Opening the menu

- Press the  menu button.

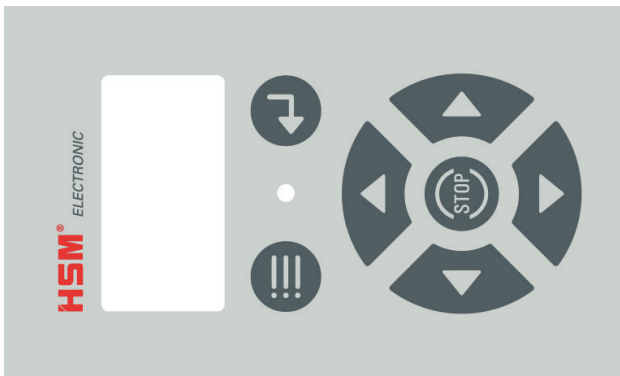
Use the control keys  to switch between the menu items:

**Operating mode - Bale ready - Actual values - Settings - Language - Bale length - Press stroke - System**

*The System menu is only accessible for HSM service engineers.*

<p>Selecting menu items:</p> 	<ul style="list-style-type: none"> <li>• Press the  menu button.</li> <li>• Use the  or  buttons to scroll through the menus.</li> <li>• Press the  Enter button to select the menu item.</li> </ul>
<p>Selecting sub-menus:</p> 	<ul style="list-style-type: none"> <li>• You can scroll through the sub-menus using the  and  buttons.</li> <li>• Press the  Enter button to select a sub-menu item.</li> </ul>
	<ul style="list-style-type: none"> <li>• This button is only available for <b>Actual values: Bales / Day</b></li> <li>• Press the  for two seconds to reset the value to zero.</li> </ul>

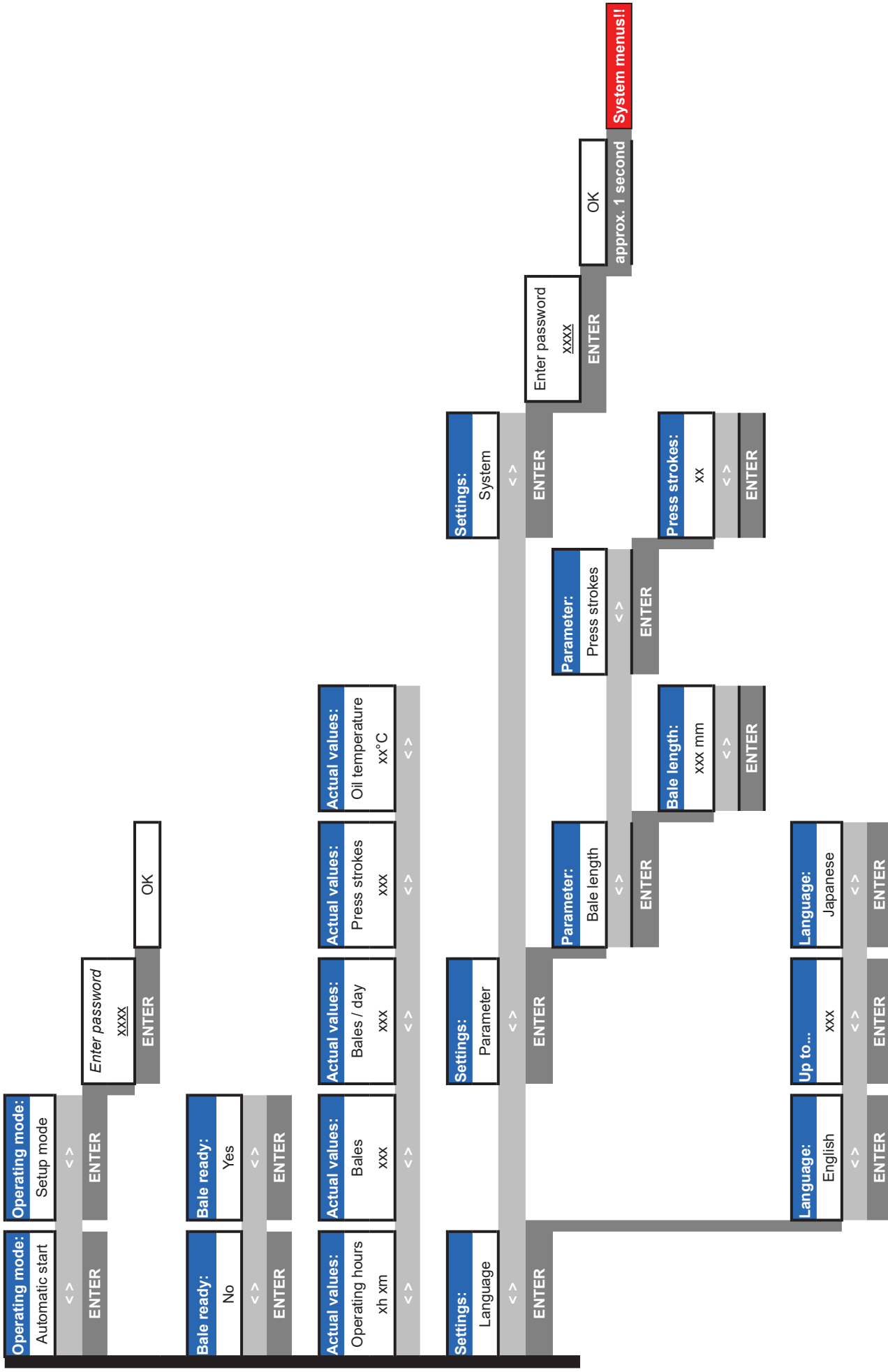

## 4.1.2 Selecting the setup mode





### **Caution!**



*In setup mode, certain electrical safety functions are disabled.  
Only specially trained staff may operate the machine in setup mode.*

***This section is password-protected.***



### Moving the press ram forwards ( button)

If you press the  button, the press ram moves forwards. If you release the  button, the press ram stops.

### Moving the press ram backwards ( button)

If you press the  button, the press ram moves backwards. If you release the  button, the press ram stops.

#### 4.1.2.1 Opening the press channel

- Select the press channel menu item
- Open the press channel 
- Press the  button to open the press channel.

## 4.1.3 Setting the user language

The text display can be set to various languages.

Press the  menu button and go to the “**User language**” using the  control keys.

Use the 4 and 6 control keys to scroll to the required language “E”.

Press the Enter button (  ) to save the required language.



#### 4.1.4 Actual values

You can call up the following actual values:

- Operating hours
- Bales
- Bales / day
- Press strokes
- Oil temperature

#### 4.1.5 Automatic start operating mode

**Automatic start operating mode means:**

- The FA 500.3 is switched on and ready for operation.
-  “Automatic start” operating mode has been selected.
- In the display, the  symbol appears.
- The pressing cycle runs automatically as long as the light barrier in the hopper is broken by material to be pressed.

The press ram moves

forward and compresses the press material. After the compression time has expired, the press ram automatically moves back to the rear limit position.

The motor switches off automatically after a set run-on time.

Once the set bale length has been reached, the “Bale ready” message appears in the display.



**Note:**



*If you press the  menu button twice, the “Automatic Start” switches off immediately.*



*The press goes into manual mode and the press ram can be moved forwards or backwards.*

***The automatic start must be reset again each time it is switched on using the main switch!***



#### 4.1.7 Displaying actual values

- Press the  button.
- Use the  buttons to switch to the “Actual values” menu item.
- The following actual values can be selected:
- 
- **Operating hours - Bales - Bales / Day - Press stroke - Oil temperature**

Actual values:	
Operating hours	<ul style="list-style-type: none"> <li>• The operating hours are shown in hours and minutes.</li> </ul>
Bales	<ul style="list-style-type: none"> <li>• Total number of bales is shown.</li> <li>• This value cannot be reset.</li> </ul>
Bales / day	<ul style="list-style-type: none"> <li>• Bales per day is shown.</li> <li>• You can reset this value to zero by pressing the  button.</li> <li>• Hold down the  button for two seconds.</li> </ul>
Press strokes	<ul style="list-style-type: none"> <li>• Total number of press strokes is shown.</li> </ul>
Oil temperature	<ul style="list-style-type: none"> <li>• The current oil temperature is displayed in xx °C</li> </ul>

## 4.1.8 Settings

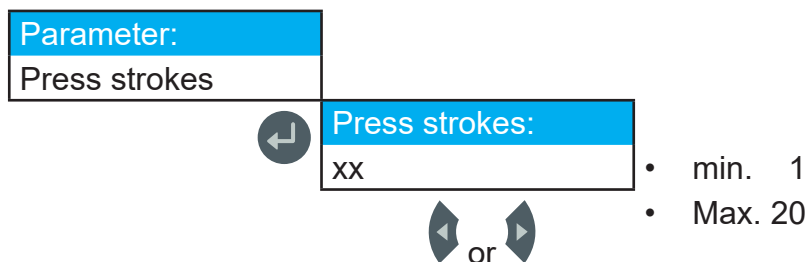
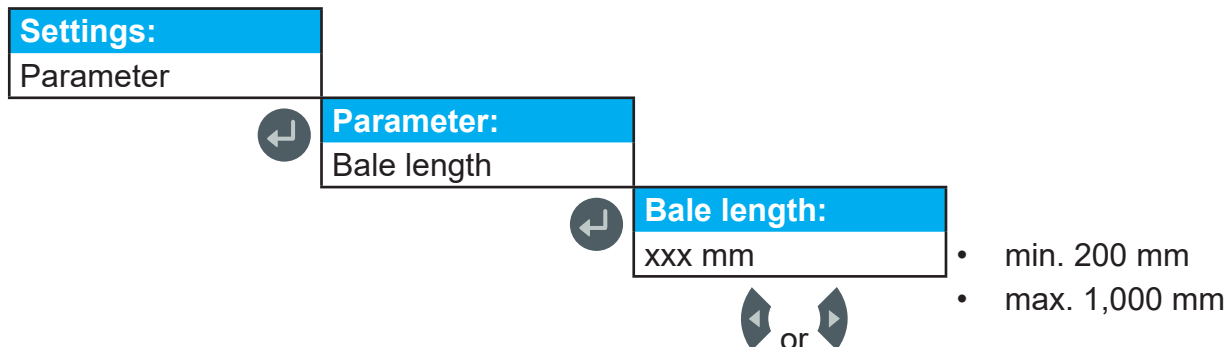
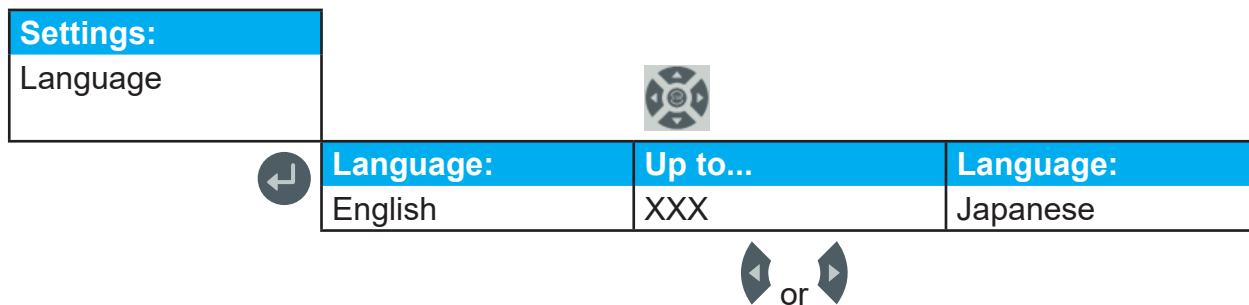

<b>Settings:</b>	
Language	<ul style="list-style-type: none"> <li>• Setting the language</li> </ul>
Parameter	<ul style="list-style-type: none"> <li>• The following parameters can be defined here.</li> <li>• Bale length</li> <li>• Press strokes</li> </ul>
Bale length	<ul style="list-style-type: none"> <li>• from min. 200 mm</li> <li>• to max. 1,000 mm</li> </ul>
Press strokes	<ul style="list-style-type: none"> <li>• from a minimum of 1 press stroke</li> <li>• to a maximum of 20 press strokes</li> </ul>
System	<ul style="list-style-type: none"> <li>• For HSM Service only</li> </ul>

## 4.2 Shredder control panel

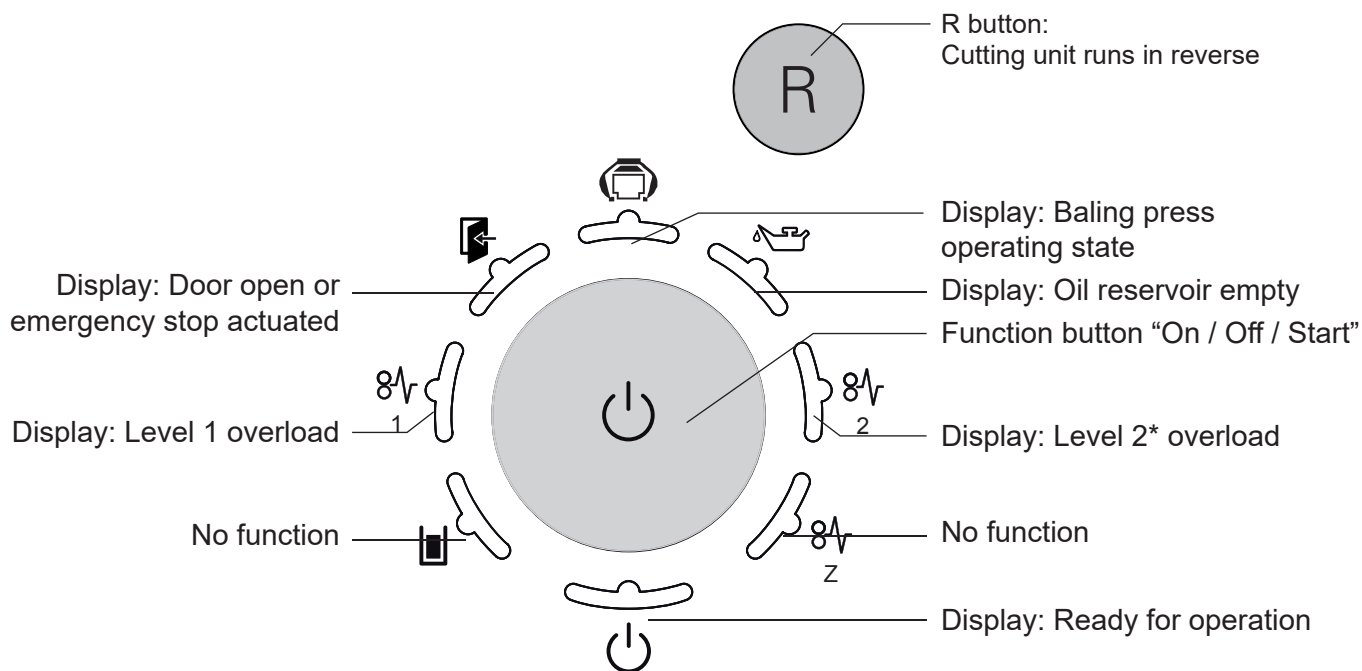

### Note

*The shredder can only be operated when the press is in the automatic mode (automatic start).*

### 4.2.1 Display: Baling press not in automatic mode

This symbol lights up red if the press is not in the automatic mode.

### 4.2.2 Display: Baling press operating state

This symbol lights up

- green when the baling press is in automatic mode.
- yellow when the bale is ready for strapping.
- red if a fault occurs in the baling press.

## 4.3 Initial start-up

- Open the inspection flap on the loading hopper and check that the press chamber is clear. Remove any spare parts or supplies delivered with the machine.
- Insert the CEE plug into the socket on-site.
- Activate the emergency stop control by pushing the switch bar away from the machine.
- Unlock the emergency stop on the press.
- Turn on the main switch on the press and shredder.

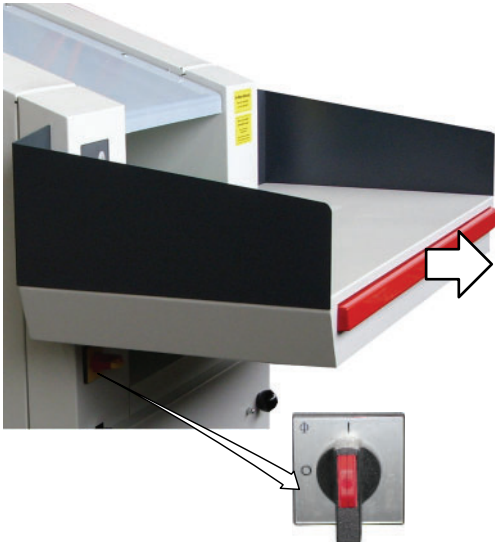

- After a control unit self-test, the **Display** shows: **Manual operation**  
**Target xxx Actual xxx**
- If the error numbers 108 (= phase missing) or 107 (=reversed rotation) appear in the display > consult an electrician. (See also the “Malfunctions” section)



### **Warning!**

*Faults in electrical components and supply cables may only be attended to by qualified electricians or HSM service engineers.*

- Close the control cabinet before the initial start-up begins.
- Select the required language
- Set the required bale length and no. of strokes of the press cylinder. *Default factory settings: bale length of 500 mm / no. of strokes depends on material*

## 4.4 Loading the baling press

- Place the wooden frame (460 mm x 460 mm wooden block: 120 mm x 120 mm) in the press channel

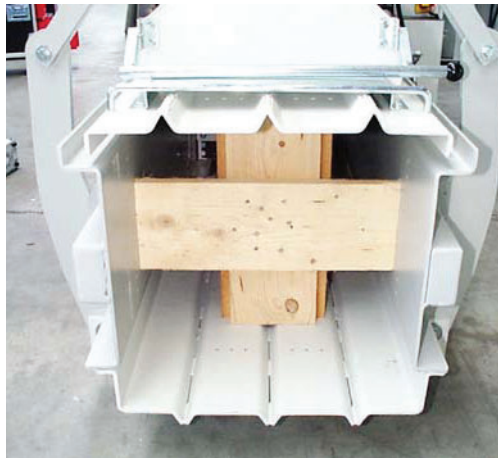



- Press the “*Press ram forwards*” button (arrow in compression direction)
  - The press ram moves forward, automatically switches to reverse and then stops in its starting position.
  - By pressing the Stop button you can stop the press ram at any position and then press the “*Press ram forwards*” or “*Press ram back*” buttons to continue.



- Move the press ram approx. 2x back and forwards in manual mode
  - This braces the wooden frame in the press channel (this step is only necessary if the press channel has been dismantled or the wooden frame is not yet braced)



- Set the “Automatic start” on the press.
  - **Menu > Operating mode > Automatic Start** (  +  )



- The “Ready for operation” display on the shredder lights up green.



- The “Baling press operating state” display on the shredder lights up green.



- Press the start button
- The cutting unit and feed belt start up

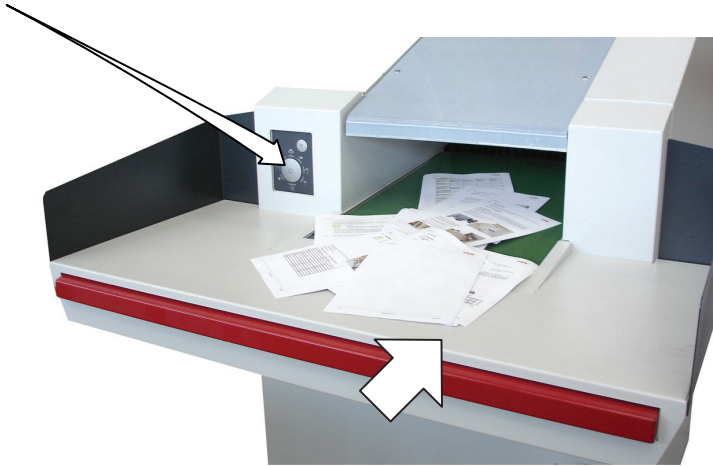

- Place the material to be shredded on the loading table and then place batches on the feed belt.

If material that is not supposed to be shredded is mistakenly placed onto the conveyor belt do not try to pull it out, instead

- Press the start button again
- The drive stops
- Press the R button
- The cutting unit and feed belt run in reverse



- When the R button is released, the shredder comes to a stand still
- You can now remove the material from the belt and start the shredder again by pressing the start button.



#### **Note**

*Provided the cutting unit is running in the shredding direction, you can stop it by pressing the R button.*

The shredded material falls through the discharge chute of the shredder directly into the press chute.

The press cycle is initiated by the light barrier in the chute when it has filled up to a certain level. The press ram moves forward and compresses the material. After the compression time has expired, the press ram automatically moves back to the rear limit position. The shredder continues to run during the pressing cycle.

- Feed material into the shredder until the wooden frame is ejected at the end of the press channel by the ongoing pressing cycle.
- Turn off the main switch on the press.
- Insert the 3 strapping tapes (as described in chapter 4.5)



**Note**

*The first bales produced after loading will not be perfectly shaped or compressed. Even if the press material is compressed a second time, it will still not produce a perfect bale.*

- Turn on the main switch on the press again.
- Fill the unstrapped “pressing material” from the start of the loading procedure in the press again through the inspection flap.
- Close the inspection flap.
- Press the “Press ram forwards” button and compress all the material in this way.
- Following this, select  Menu > Operating mode > Automatic start.
- You can then carry on working in automatic mode.



#### 4.4.1 Setting the press channel adjustment cylinder

The material is compressed and pushed into the conical press channel. The press channel opens and closes depending on the pressure.

The opening speed of the press channel can or must be adjusted depending on the type of material to be pressed (frictional resistance).



**Note**

*The press channel should open smoothly – not with a sudden jerk.*

**Close** the throttle screw to open the press channel more **slowly**  
**Open** the throttle screw to open the press channel more **quickly**

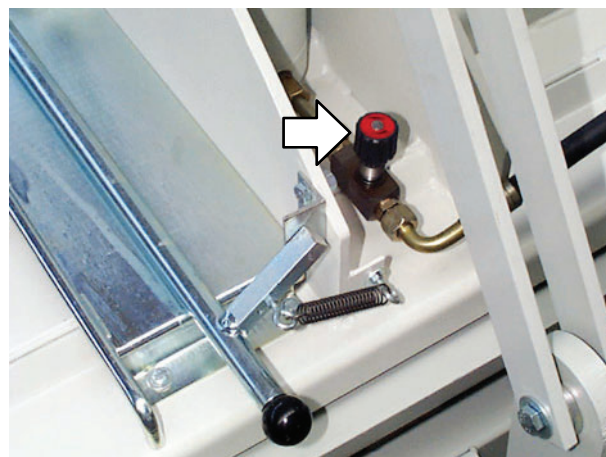

Starting position:

Close the throttle screw completely and then open it by **1/8 of a turn**.



#### 4.4.2 Relieving the press channel

The press channel has to be relieved:

- a) before maintenance work
- b) if the press channel needs to be emptied or dismantled
- c) if the pressing power of the cylinder is no longer sufficient to cut off or push the material to the front in the conical press channel. (Shearing fault)
  - Press the  +  buttons at the same time.
  - the press channel is decompressed, which means the adjusting cylinder lowers.



**Note**

*This applies to both manual and automatic operation.  
It is also possible to relieve the press channel during operation.*



## 4.5 Inserting the strapping tape

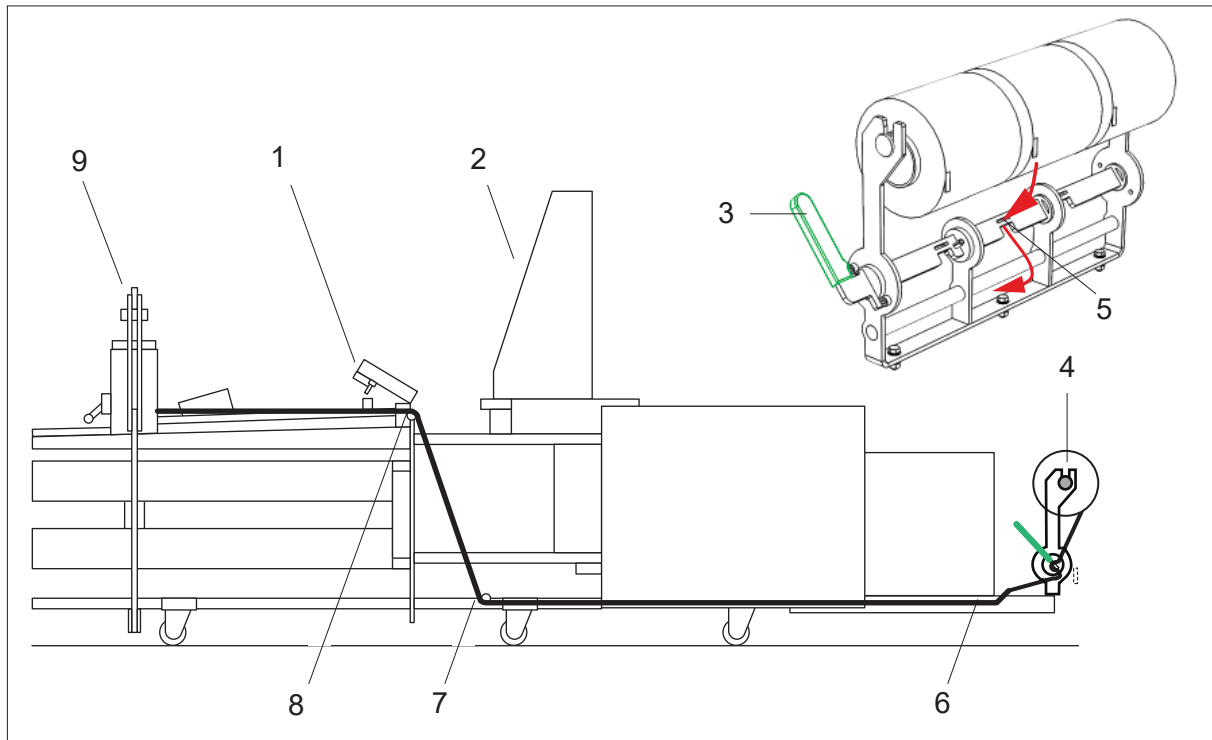

- Open the strapping flap (1) and the inspection flap (2) on the loading hopper
- Pull off the strapping tape (4) from the reel
- Open the tape brake (3) and pull the strapping tape through the slot (5)
- Slide the strapping tape along the pipe (6) until the tape comes out the press chamber (7) at the front
- Pull the strapping tape up and through the eyelet (8)
- Pull the strapping tape along until the press channel adjustment (9) and leave it on the cover, so that the tape can unravel when the bales are compressed



### **Caution!**

*Never tie the end of the tape to the press channel otherwise the tape will snap.*

- Close the strapping flap.
- Wind the loose tape round the tape reel and close the tape brake

## 4.6 Automatic compressing using the light barrier



- Press  Menu > Operating mode > Automatic start
- The yellow “Automatic mode” LED lights up

- You can now start running the shredder with continuous feed

In this setting the press ram moves back and forth automatically as long as the light beam in the shaft is interrupted by pressing material.

Once the bale length/number of strokes is reached, the “*Bale ready - Strap bale*” message appears in the display and the press ram remains in the foremost position.

## 4.7 Sequence for “Strap bale” and “Strapping”

The press ram moves into the fully extended position and remains under pressure in the “Strapping” position. The bale can now be strapped three times. To do this, proceed as follows:

- Open the strapping flap (1) and release the tape brake

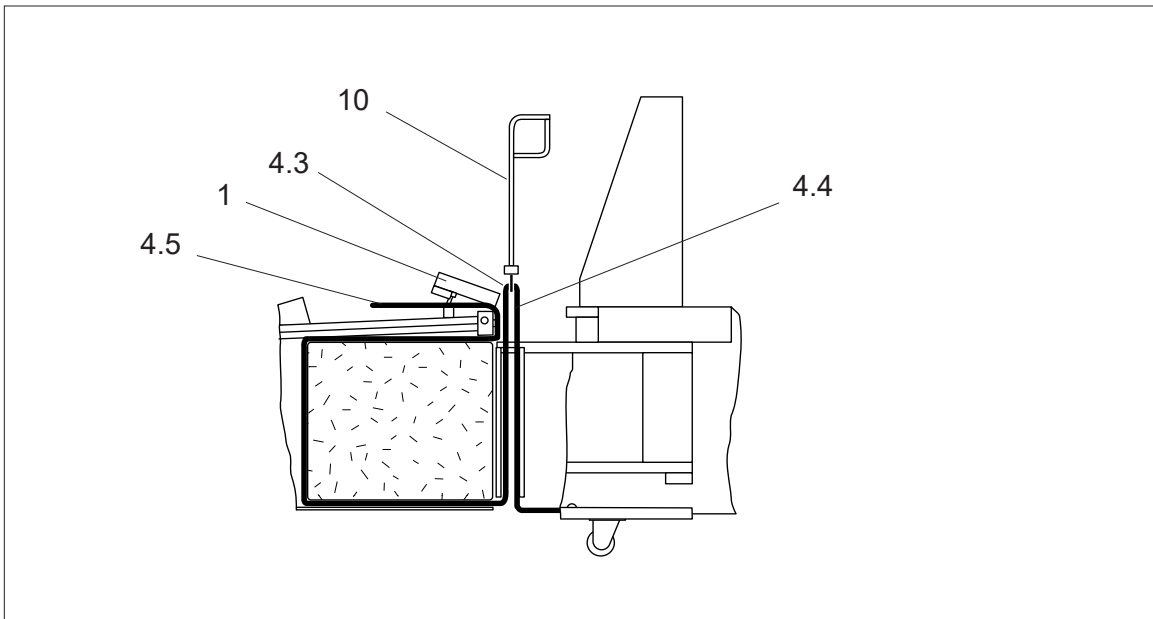

- Check whether the channels are free of material in the press ram and clear the channels if necessary using the tape insertion needle (10)

- Push the tape insertion needle (10) down through the first strapping channel of the press ram
- By turning the tape insertion needle 90°, the claw grabs the loose hanging tape
- Pull the threaded strapping tape up and put the tape insertion needle aside
- Cut through the tape loop with a knife or scissors and tie the end of the tape (4.5) to the other end (4.3)



**Note**

*Do not mix up the (4.3) and (4.4) tape ends.  
Otherwise the bale strapping will not be possible.*

- Pull the cut-off tape (4.4) again through the eyelet and then along up to the press channel adjustment.



**Caution!**

*Never tie the end of the tape to the press channel otherwise the tape will snap.*



- Repeat in the same way for the 2nd and 3rd strapping procedures
- Close the strapping flap (1) and the tape brake



**Warning!**

*If the channels in the press ram are not properly cleared, it can cause strapping tape to get caught in the press ram and be pulled along when the press ram retracts.*

*Never hold on to tape that is caught in the machine!  
This could result in injuries to the hands and fingers from crushing and cuts.*

- A new, automatic pressing process can now be started with the  +  “Automatic start” buttons.

## 4.8 “Polythene bag attachment” sequence

- Lift the clamping bracket assembly (11).
- Fit a plastic bag (12) over the outlet and pull it over the slide plate (13).
- Lower the clamping bracket assembly (11).
- The finished bales will not be automatically pushed into the plastic bag.



Accessories material:  
Plastic bag

item no.: 1 452 995 000

## 4.9 Baling press malfunctions

As soon as a malfunction occurs in the baling press, the red malfunction symbol  lights up. Switch off the baling press and shredder and an error message appears in the text display.



The “Baling press operating state” symbol  on the shredder lights up red.

The previous error number is saved in the error memory.

By pressing the +/- buttons at the same time or switching on and off, the system can delete various error messages displayed.

**Service hotline: +49 75 54 2100 300**

### 4.9.1 Error numbers

Code		Description	Remedy
100	SLS. 08. 001	Communication PIC <-> ATMEL	Electrician! Call HSM Service!
101	FLS. 08. 040	Contactors defective	Electrician! Call HSM Service!
102	SLS. 08. 023	Motor protection has been triggered.	Electrician! Call HSM Service!
103	FLS. 08. 053	Press cylinder feedback	Electrician! Possible cable rupture or defective solenoid valve!
104	FLS. 08. 049	Hydraulic locking mechanism feedback	Electrician! Possible cable rupture or defective solenoid valve!
105	FLS. 08. 056	Hydraulic channel adjustment feedback	Electrician! Possible cable rupture or defective solenoid valve!
106	FLS. 08. 053	Press timeout	Call HSM Service!
107	FLS. 08. 032	Reversed rotation	Phase is reversed Electrician! Replace phase!
108	FLS. 08. 033	Phase fault	Electrician! Phase missing
109		EEPROM CRC fault	Electrician! Call HSM Service!
110	FLS. 08. 009	Pressure switch defective	Electrician! Call HSM Service!
111	ZD. 02 .236	Excess hydraulic oil temperature	Let motor cool down - wait approx. 20 minutes
112	FLS. 08. 019	Open/ruptured hydraulic oil temperature sensor	Electrician! Call HSM Service!
113	FLS. 08. 020	Short circuit in hydraulic oil temperature sensor	Electrician! Call HSM Service!
114	FLS. 08. 008	Door switch defective	Electrician! Call HSM Service!
115	FLS. 08. 037	Channel switch not seen	Electrician! Call HSM Service!
116	FLS. 09. 059	Maximum motor runtime achieved	Switch off for 5 minutes and wait! Call HSM Service!
117	ZD. 04.038	Light barrier interrupted	Remove material bridge / clean light barrier
118	FLS. 08. 118	Shearing fault	Remove material jam
119	FLS. 08. 004	UPPER proximity switch defective, only KP40	Electrician! Call HSM Service!
120	FLS. 08. 003	LOWER proximity switch defective, only KP40	Electrician! Call HSM Service!
121	FLS. 08. 001	FRONT proximity switch defective	Electrician! Call HSM Service!
122	FLS. 08. 002	REAR proximity switch defective	Electrician! Call HSM Service!
123	FLS. 08. 057	Oil cooler contactor does not tighten	Electrician! Call HSM Service!

## 4.10 Shredder malfunctions

### 4.10.1 Overload due to paper jam



- “Overload” display (level 1 or level 2 - depending on machine version) lights up red.
- The drive automatically runs in reverse for several seconds. Then the cutting unit switches off.



#### **Caution!**

*The blade rollers can still cause injuries even while they are not running.*

*Do not reach into the cutting unit!*

*Protective gloves should be worn at all times.*

*Do not move the cutting unit run forwards and backwards alternately to remove any blockages. This will damage the shredder.*



- Remove the stack of paper.





- Set “Automatic start”  +  on the press.
- Press the start button and put less paper on the feed belt.

### 4.10.2 Electric motor overheats



- “Overload” display (level 1 or level 2 - depending on machine version) flashes red.
- The drive switches off automatically.



- Let the motor cool down for 20–30 minutes.
- Press the  +  “Automatic start” buttons on the press.
- Press the start button.



### 4.10.3 Emergency stop actuated



- Display lights up red.
- The baling press and shredder switch off.

- Activate the emergency stop control by pushing the switch bar away from the machine.



- Press the  +  “Automatic start” buttons on the press.
- Press the start button.

#### 4.10.4 Oil reservoir empty



- “Oil reservoir empty” display lights up blue.
- Top up with special lubricating oil for the cutting head.  
Order no. 1.235.997.500 for 5 l container
- The “Oil reservoir empty” signal is automatically deactivated once the reservoir has been filled.



#### **Note**

*The shredder remains operational even when the oil reservoir is empty.*

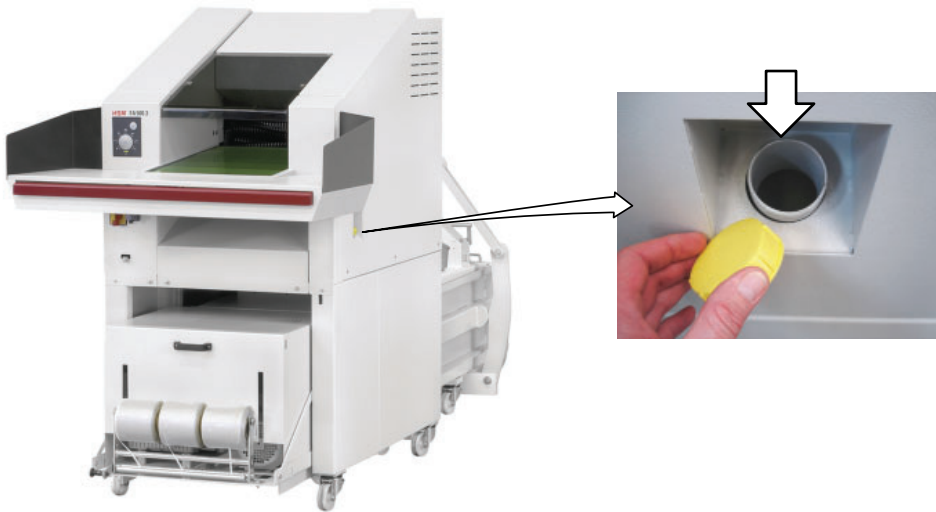

#### 4.11 Stopping the machine

- Put the machine in the starting position (press ram at the rear).
- Turn off the main switch on the shredder and baling press.
- Secure the main switch against restarting.
- Disconnect the red CEE power plug.

#### 4.12 Outdoor operation



#### **Warning!**

*For reasons of safety, the machine may only be operated under supervision.  
The operator must ensure that no unauthorised persons have access to the machine.  
When the machine is not being used, it must be shut down and secured against unauthorised use.*

See also the “Installation conditions” chapter

## 5 Inspection and maintenance work

### 5.1 Notes on maintenance



**Note**

*Malfunctions which are due to inadequate or incorrect maintenance can lead to expensive repairs and lengthy machine down-times. Regular maintenance is therefore essential. For this reason we recommend a maintenance and inspection contract.*



**Warning!**

*Correct any damage immediately. Escaping oil can cause a fire and injury.*

*Maintenance and repair work on the electrical system or control cabinet may only be carried out by a qualified electrician or one of our service engineers.*

All the inspection and maintenance tasks listed here apply to **single-shift operation**. The intervals must be reduced accordingly for multiple shift operation. The baling press must undergo a complete overhaul at least every two years.

Always refer to the “*Safety*” section during maintenance and inspection work.

Before performing such tasks, make sure the drives and additional mechanisms of the baling press cannot be switched on unintentionally. Turn the main switch to the “0” position and secure it. Pull out the red CEE plug.

Maintenance work may only be carried out by our specialist engineers or specially trained staff.

Only persons with the appropriate skills and experience in hydraulics may carry out work on the hydraulic equipment.

Empty the press channel before performing repair or maintenance work on the baling press. (see chapter on “Relieving the press”)



## 5.2 Maintaining the baling press

### 5.2.1 Changing the hydraulic fluid/ventilation filter

Change the hydraulic fluid and ventilation filter **every 2 years**

- Move the press ram to its rear limit position.
- Turn off the main switch and pull the red CEE plug out.
- Remove the 2 screws (1) at the side on the cover hood.
- Lift out the tape reel shaft 2) with the tape reel and place them on the floor.
- Remove the cover (H).



Ventilation filter  
Order no. 6.116.195.090

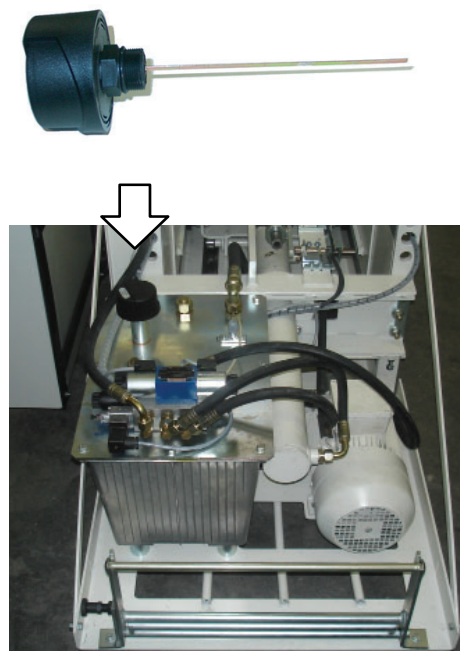

- Remove the lid of the tank and drain the oil with a fluid suction unit.
- The capacity of the hydraulic oil tank is 27 l.
- If the hydraulic oil tank is very dirty, clean it.
- Put the lid back on again.
- Fill up with oil until the oil level is between the two notches on the oil level dipstick.

Oil type:

- Multigrade oil according to DIN 51524-T3 / ISO viscosity class HVLP 32.

	ISO- Viskositäts- klasse	ESSO	DEA	SHELL	ARAL	BP	FINA
Mineralöle Mineral oils	ISO VG 32 HVI 32	UNIVIS N 32	Astron HLP 32	Tellus Öl T 32	Aral Vitam HF 32	Bartran HV 32	HYDRAN HV 32

- Move the press ram forward and back several times and check the oil level again with the press ram in its front limit position.
- Fill up with oil if required.
- Screw in a new venting filter.
- Fit the cover (H) again.
- Insert the tape reel shaft (2) again.



**Note**

*Observe the applicable accident prevention regulations when handling cleaning agents and solvents.*

*Observe the environment protection regulations when disposing of waste oil.*

*Never mix hydraulic fluid and cleaning agent mixtures with waste oil. Collect these substances in separate containers and dispose of them according to the regulations.*

## 5.2.2 Lubricating moveable parts

The press ram guide is largely maintenance-free. The installed rollers are provided with life-long lubrication.

The lateral guide elements are made of wear resistant, fibreglass-reinforced plastic. Lubricate all movable parts and hinges, especially the door hinges and the bearings of the door locks as required.

### 5.2.3 Emptying the dirt drawer

- Turn off the main switch.
- Empty the dirt drawer under the baling press every week.
- Make sure that the safety lock latches in when the drawer is pushed in.
- Clean the area under the baling press -> apply suction to dirt particles!



## 5.3 Maintenance of the FA 500.3 shredder

### 5.3.1 Lubricating the drive chains and synchronous wheels (twice a year)

- Turn off all the main switches and pull the red CEE plug out.
- Remove the inspection flaps (1) in the left and right side plates. Take out the Allen screws (2).
- Grease the drive chains from the motor to the cutting unit, the cutting unit to the conveyor belt and the synchronous wheels.  
Recommended lubricating grease: K2K in line with DIN 51502/DIN 51825

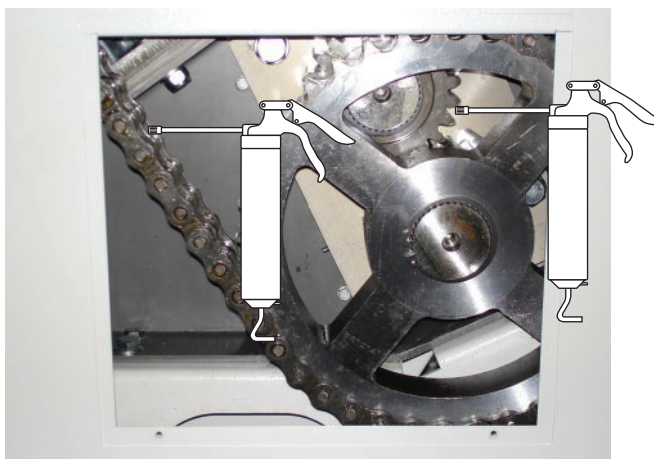
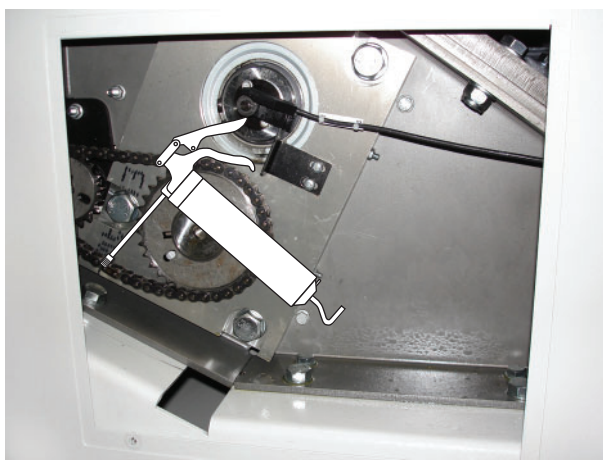

- Mount the inspection flaps onto the unit again.

### 5.3.2 Tightening the tension on the conveyor belt

- Turn off the shredder.
- Loosen the hex nuts (3) on the left and right sides of the snub roller (accessible from below).
- Loosen the lock nuts (4) of the tensioning bolts (5).
- Use the tensioning bolts to tension the conveyor belt evenly.

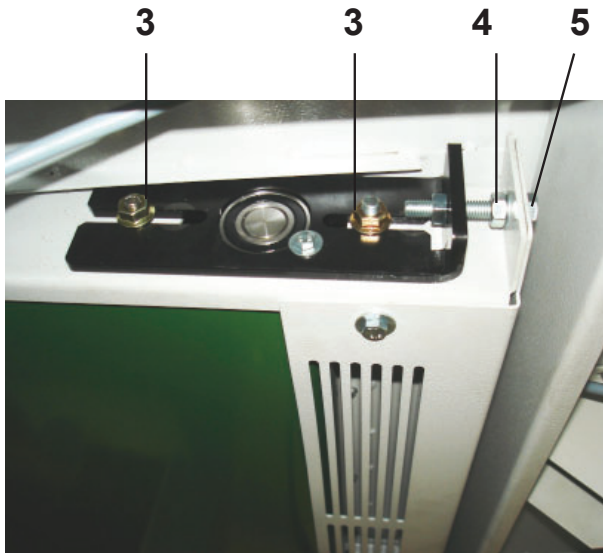

#### **Note**

*Only tighten the conveyor belt until it stops slipping. The feed belt bearing may be damaged if it is tightened too much.*

- Tighten the hex nuts on the snub roller and the lock nuts on the tensioning bolts again.

### 5.3.3 Checking the directional stability of the conveyor belt

Switch on the shredder and let it run for approx. 10 minutes. During this time, the conveyor belt must run in the middle of the snub roller. If it slips to the left or right edge, you must alter the setting of the snub roller.

### 5.3.4 Checking the conveyor belt for wear

The surface of the conveyor belt can become worn after long periods of use. If you can see the fabric inlay in the belt, it must be replaced. Please notify our customer service.

### 5.3.5 Emptying the sump tray

- Empty the dirt drawer under the conveyor belt as required
- Clean the area under the shredder -> apply suction to dirt particles!



## 6 Storage

If the shredder and baling press combination has to be put into storage for a longer period of time, make sure that:

- The shredder and baling press combination is disconnected from the power supply.
- The shredder and baling press combination is not directly exposed to the weather.
- The hydraulic tank, pipes and hoses have no leaks.

## 7 Disposal information

HSM baling presses and shredders have a long service life. Nevertheless, every machine reaches a time when inspections and repairs are no longer worth the trouble. The operator then faces the problem of disposing of the machine properly.

We will be glad to advise you about the legal regulations for disposal at the appropriate time.

The baling press and shredder are made of various materials and must therefore be dismantled for recycling separately. (Ferrous materials, electrical parts, plastics).

The hydraulic tank, pipes and hoses must be emptied. Make sure that overflowing or sprayed fluids are cleared up with suitable bonding agents or technical equipment and are not able to penetrate water, the ground or the drainage system.

Observe the national legal regulations for the removal of the respective hydraulic fluids.

## 7.1 Disposal verification form

To

**HSM** GmbH + Co. KG

Austrasse 1-9

88699 Frickingen / Germany

The machine specified here

Designation:            Baling press / shredder

Model: \_\_\_\_\_

Machine number: \_\_\_\_\_

Year of construction: \_\_\_\_\_

has been disposed of according to the applicable regulations.

Address of the previous  
operating company

Address of the disposal  
company

.....  
Date and signature  
of the previous operator

.....  
Date and signature  
of the disposal company



## 8 Using and ordering spare parts

**Only use original spare parts from HSM!**

If you would like to order spare parts, please always state the:

- **full machine number**
- **year of construction of the baling press**

<b>HSM</b> ®		HSM GmbH+Co.KG Austrasse 1-9 D-88699 Frickingen Germany	
MODELL		CE	
MASCH.-NR.:	<input type="text"/>		
SERIEN - NR.:	<input type="text"/>		
PRESSKRAFT:		kN	
SPANNUNG:	V	Hz	LEISTUNG: kW
BAUJAHR:			NENNSTROM: A

### 8.1 Customer service address

**HSM GmbH + Co. KG**  
Austrasse 1-9  
88699 Frickingen, Germany  
Tel. +49 7554-2100-300  
Fax +49 7554-2100-197  
support@hsm.eu

## 9 Circuit diagrams

The electrical wiring diagram and the hydraulic plan are summarized in H+E wiring diagram. The H+E wiring diagram is located in the control cabinet.

## 10 Declaration of Conformity

# Declaration of Conformity

The manufacturer **HSM GmbH + Co. KG**  
**Austrasse 1-9**  
**D - 88699 Frickingen**

hereby declares that the **SP 5088 shredder and baling press combination**, consisting of the FA 500.3 document shredder and the KP 88.2 baling press, meets the fundamental health and safety requirements of the following EU directives:

Supply of Machinery (Safety) Regulations 2008  
Electromagnetic Compatibility Regulations 2016

*Applied standards and technical specifications:*

BS EN ISO 4413:2010	BS EN ISO 11202:2010+A1:2021	BS EN ISO 12100:2010
BS EN ISO 13849-1:2015	BS EN ISO 13851:2019	BS EN ISO 13854:2019
BS EN ISO 13855:2010	BS EN ISO 13857:2019	BS EN ISO 14118:2018
BS EN ISO 14119:2013	BS EN ISO 14120:2015	BS EN 60204-1:2018
BS EN IEC 61000-6-2:2019	BS EN 61000-6-4:2007+A1:2011	

Frickingen, 05/2022



ppa. Hubert Kötzing  
Overall Management of the Technical Area

Authorised representative for the compilation of technical documentation:  
Hubert Kötzing, HSM GmbH + Co. KG.

The technical documentation acc. to annex VII, part A has been created, and is held by HSM GmbH + Co. KG.

This declaration only refers to those machines which are in the same condition as they were when put into circulation, parts added later by the end user and/or any subsequent work are not accounted for.